



BAUCE
1970

BLUESTAR H5 15

WE INTRODUCE A NEW WORLD OF SAMMYING

BLUESTAR H5 1S



Nuovo sistema idraulico cambio feltri
New hydraulic system to change felts

IT



NUOVO SISTEMA CAMBIO FELTRI RAPIDO

Con questo nuovo sistema idraulico possiamo sollevare i cilindri pressanti utilizzando gli stessi pistoni pressanti del macchinario



ROBUSTEZZA ED AFFIDABILITÀ

Date dall'impiego di materiali di alta qualità associate alle tecniche di costruzione tra le più avanzate



POTENZA DI ASCIUGATURA

Ottenuta dall'utilizzo di un sistema totalmente idraulico con 5 cilindri disposti a calandra con 4 punti di asciugatura



RAPIDITÀ DI MANUTENZIONE

Ottenuta ponendo come obiettivo già in fase di progetto la semplice sostituzione di tutti i componenti soggetti ad usura, primo fra tutti la realizzazione di un rapido e semplice sistema per la sostituzione dei feltri



SEMPLICITÀ D'USO

Adatta all'impiego di personale non specializzato automatizzando il centraggio dei feltri, il movimento del cilindro stenditore e visualizzando sull'apposito quadro comandi lo spessore della pelle e la velocità di lavoro





NEW RAPID SYSTEM TO CHANGE THE FELTS

This new rapid hydraulic system lift the pressure cylinder using the pressure piston of the machine



STURDINESS AND RELIABILITY

Given by the use of high-quality materials in combination with the most developed construction techniques



DRYING POWER

Obtained by using a completely hydraulic system having five drying cylinders disposed in calender and with four differential pressures



RAPID MAINTENANCE

Since the planning phase, the simple replacement of all components subject to wear, especially the realisation of a rapid and simple felt replacement system



EASY TO USE

That makes it suitable for use by unskilled personnel: automation of felt centring, the movement of the spreading cylinder; the thickness of the hide and the speed of work are displayed on the control panel



BLUESTAR H5 1S



IT **IDEALE PER PELLI PIENO SPESSORE E PELLI DIVISE IN TRIPPA,
WET BLUE E WET WHITE**

EN **IDEAL FOR FULL-THICKNESS HIDES AND HIDES DIVIDED INTO PELTS,
WET BLUE AND WET WHITE**

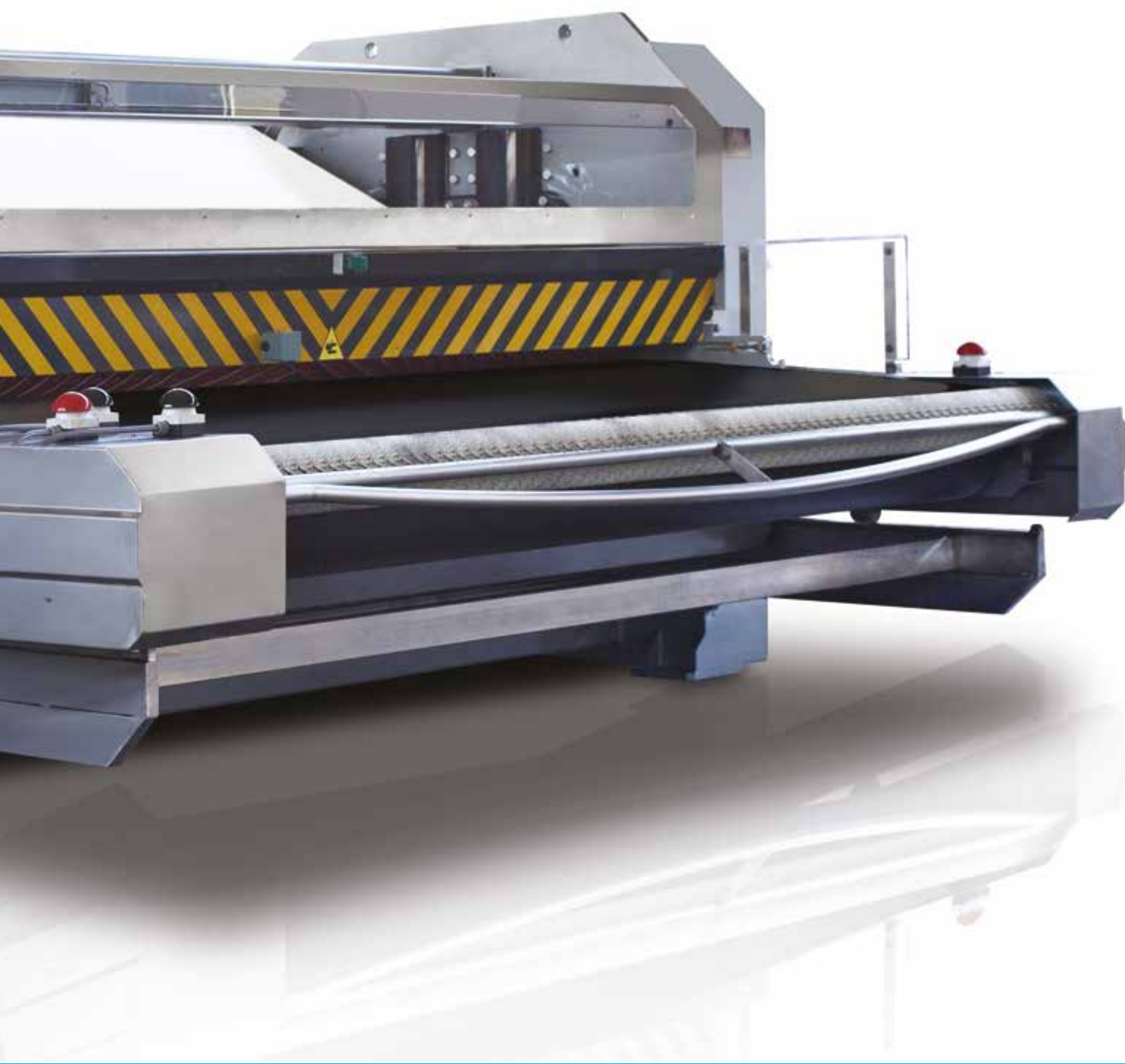

BLUESTAR H5 1S

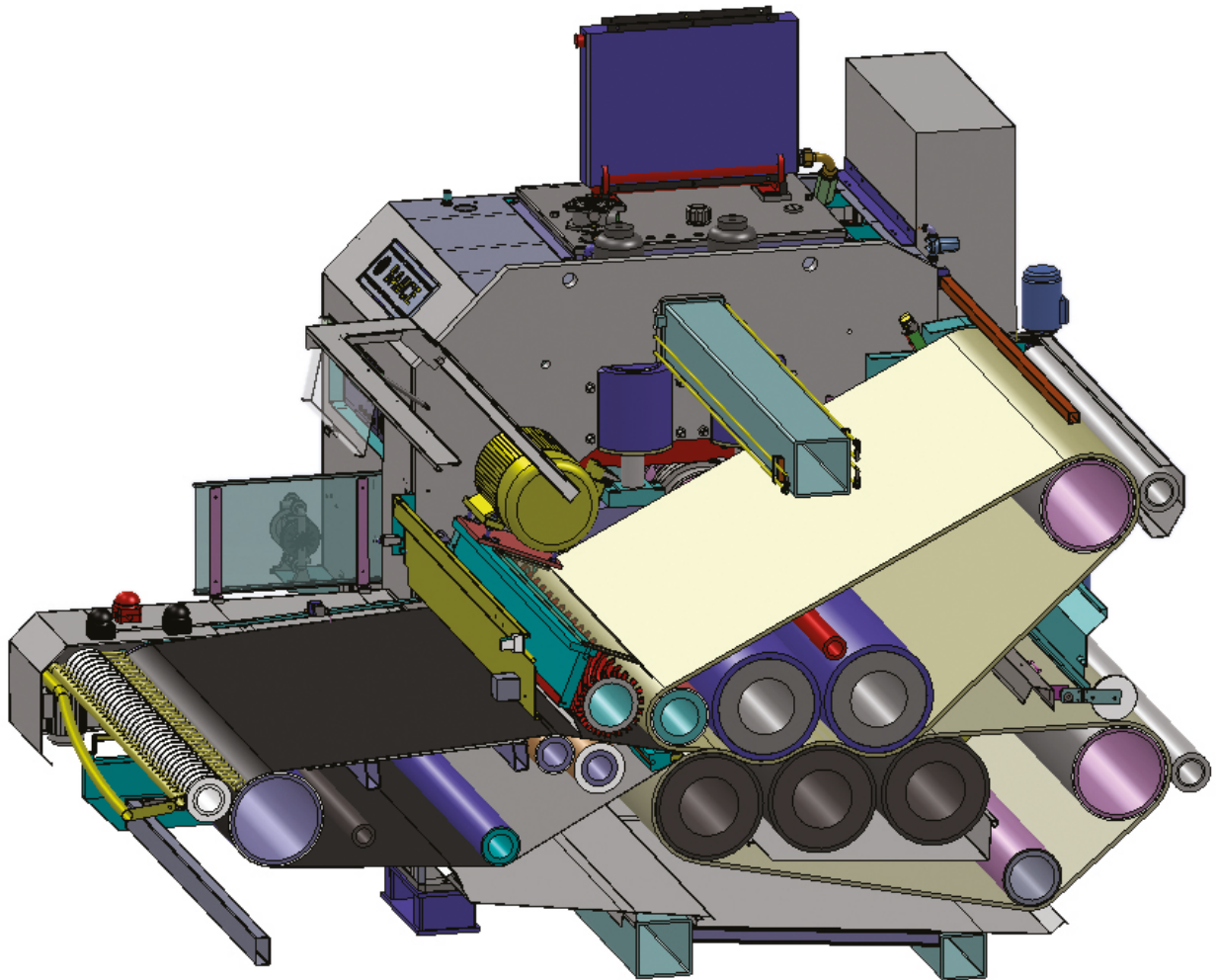

BAUCE
1970

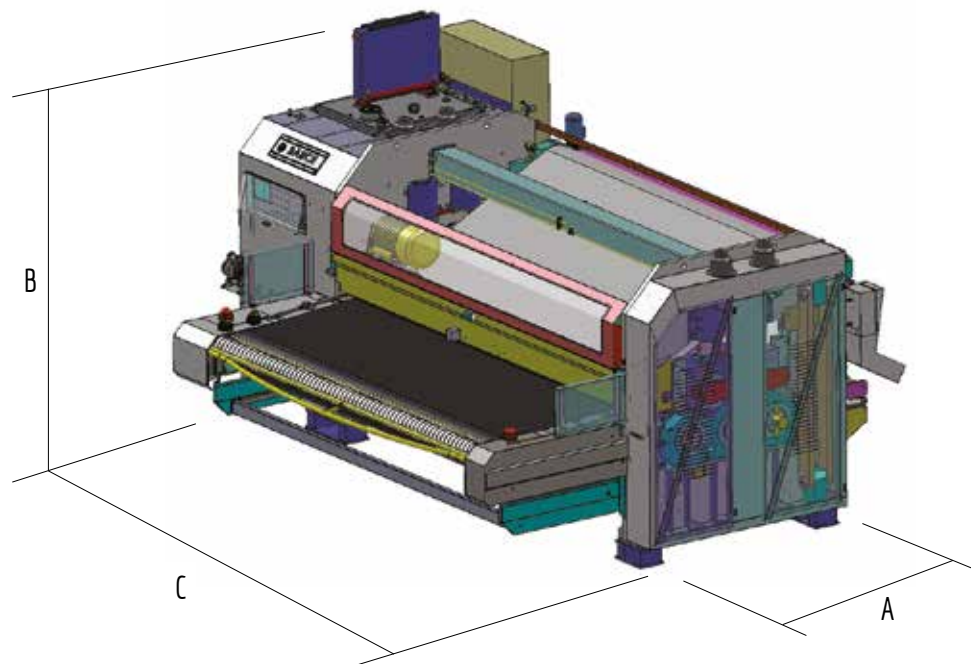

BLUESTAR H5 15

DATI TECNICI / TECHNICAL DATA

TAVOLA / WORKING WIDTH		2400	2700	3000	3200	3400
VELOCITÀ / SPEED	m/min (50hz)	8÷20	8÷20	8÷20	8÷20	8÷20
	m/min (60hz)	10÷22	10÷22	10÷22	10÷22	10÷22
POTENZA / INSTALLED POWER	kW	74	74	74	74	74
PRESSIONE D'ESERCIZIO POMPA IDRAULICA HYDRAULIC PUMP PRESSURE	bar	50÷200	50÷200	50÷200	50÷200	50÷200
OLIO / OIL	Kg	220	220	220	220	220
AL. ELETTRICA / POWER SUPPLY	vedere dati di targa della macchina					
AL. PNEUMATICA / PNEUMATIC SUPPLY	bar	6	6	6	6	6
CONSUMO ARIA MEDIO / NOMINAL AIR CONSUMPTION	Lt/m	0,1	0,1	0,1	0,1	0,1
AL. ACQUA / WATER CONNECTION	bar	2	2	2	2	2
CONSUMO ACQUA / WATER CONSUPTION	Lt/m	83	94	105	110	120
LARGHEZZA DI LAVORO / WORKING WIDTH	mm	2400	2700	3000	3200	3400
PROFONDITÀ / DEEPTH [A]	mm	3900	3900	3900	3900	3900
ALTEZZA / HEIGHT [B]	mm	2750	2750	2750	2750	2750
LARGHEZZA / LENGTH [C]	mm	4410	4710	5010	5210	5410
PESO NETTO TOT. / TOTAL NET WEIGH	Kg	17300	19500	21200	23500	24500
PESO TOT. IMBALLO / TOTAL WEIGHT	Kg	17350	19550	21250	23550	24550
VOLUME CON IMBALLO MARITTIMO VOLUME WIDTH SEA PACKING	m ³	23	24	26	27	28

BAUCE TRI.MA SRL



Head office:

Via del lavoro 27, 36070 Trissino VI ITALY



Tel. +39 0445 490740

Fax +39 0445 490068



info-line@bauce.com

www.bauce.com

Operating Unit:

Via Arzignano 33, 36070 Trissino VI ITALY

R&D Department:

Via dell'artigianato 20, 36070 Trissino VI ITALY

Bauce do Brasil

Endereço: Av. Bom Jardim, 1777, Ivoti - RS BRASIL

Tel.: +555135560555

