



BAUCE
1970

BLUEXTREME 15

WE INTRODUCE A NEW WORLD OF SAMMYING

BLUEXTREME 1S



Motorizzazione idraulica
Hydraulic engine

IT



ROBUSTEZZA ED AFFIDABILITÀ

Data dall'impiego di materiali di alta qualità utilizzati con tecniche di costruzione tra le più avanzate



POTENZA DI ASCIUGATURA

Ottenuta dall'utilizzo di un sistema totalmente idraulico con 7 cilindri di asciugatura disposti a tripla calandra con 6 punti di pressatura e con 3 pressioni differenziate indipendentemente regolabili



MASSIMA VELOCITÀ

Velocità massima di lavoro di 30mt/min grazie alla nuova pompa idraulica installata



MANUTENZIONE RAPIDA

Grazie al nuovo sistema di cambio feltri ottenuto ponendo come obiettivo, già in fase di progetto, la semplice sostituzione di tutti i componenti soggetti ad usura, primo fra tutti la realizzazione di un rapido sistema per la sostituzione dei feltri



SEMPLICITÀ D'USO

Adatta all'impiego di personale non specializzato automatizzando il centraggio dei feltri, il movimento del cilindro stenditore e visualizzando sull'apposito quadro comandi lo spessore della pelle e la velocità di lavoro





STURDINESS AND RELIABILITY

Given by the use of high quality materials in combination with the most advanced construction techniques



DRYING POWER

Obtained by using a completely hydraulic system having 7 drying cylinders disposed in triple calender with 6 points of pressure and with three differential pressures independently adjusted



MAXIMUM SPEED

Maximum speed of 30 mt/min thanks to the new hydraulic pump installed



RAPID MAINTENANCE

Right from the initial planning phase, the simple replacement of all the components subject to wear and especially the realisation of a rapid and simple felt replacement system, had been considered



SIMPLICITY OF USE

That makes it suitable for use by unskilled personnel: automation of felt centering and movement of the spreader cylinder; the thickness of the hide and the speed of the work are displayed on the control panel



BLUEXTREME 15



IT IDEALE PER PELLI PIENO SPESSORE E PELLI DIVISE IN TRIPPA,
WET BLUE E WET WHITE

EN IDEAL FOR FULL-THICKNESS HIDES AND HIDES DIVIDED INTO PELTS,
WFT BLUE AND WFT WHITE



BLUEXTREME 15

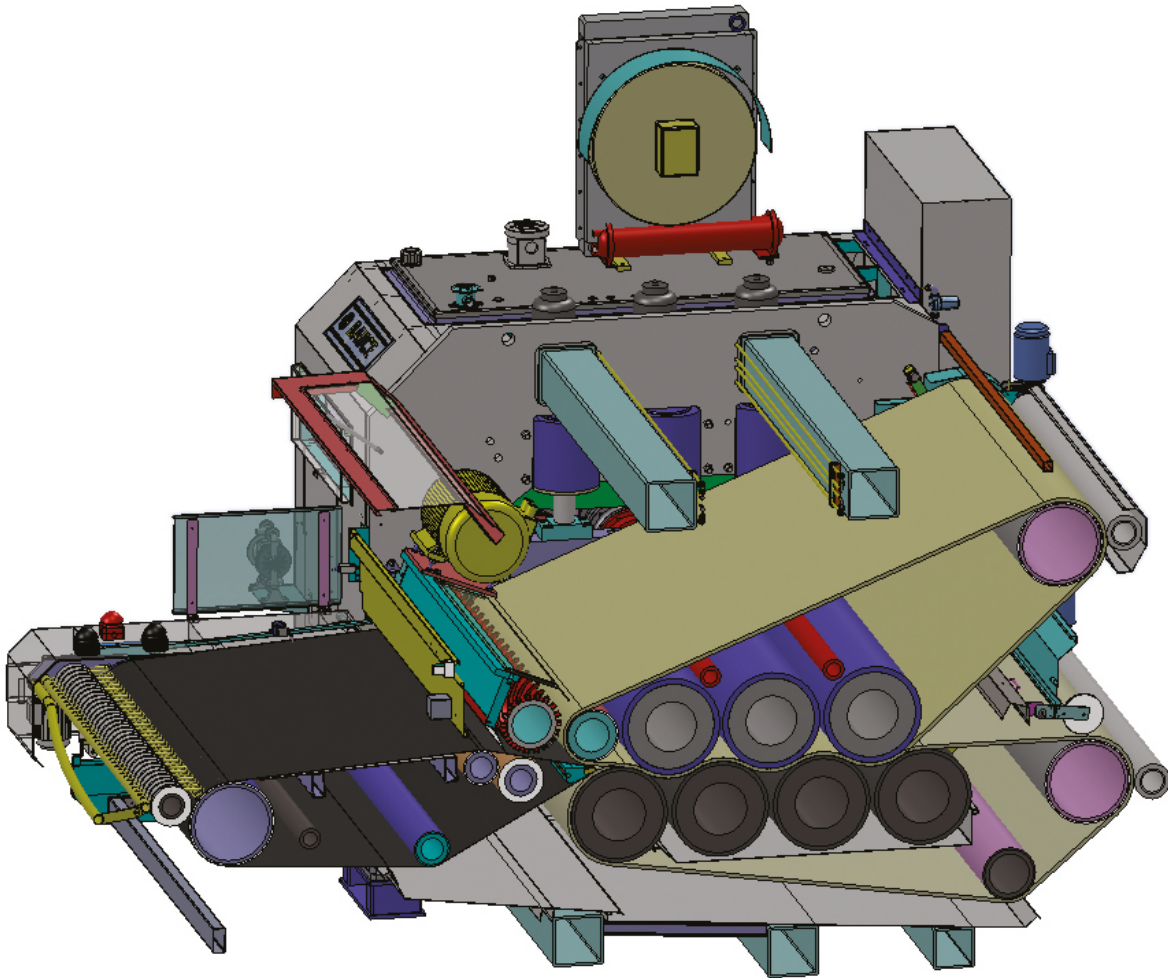

BAUCE
1970

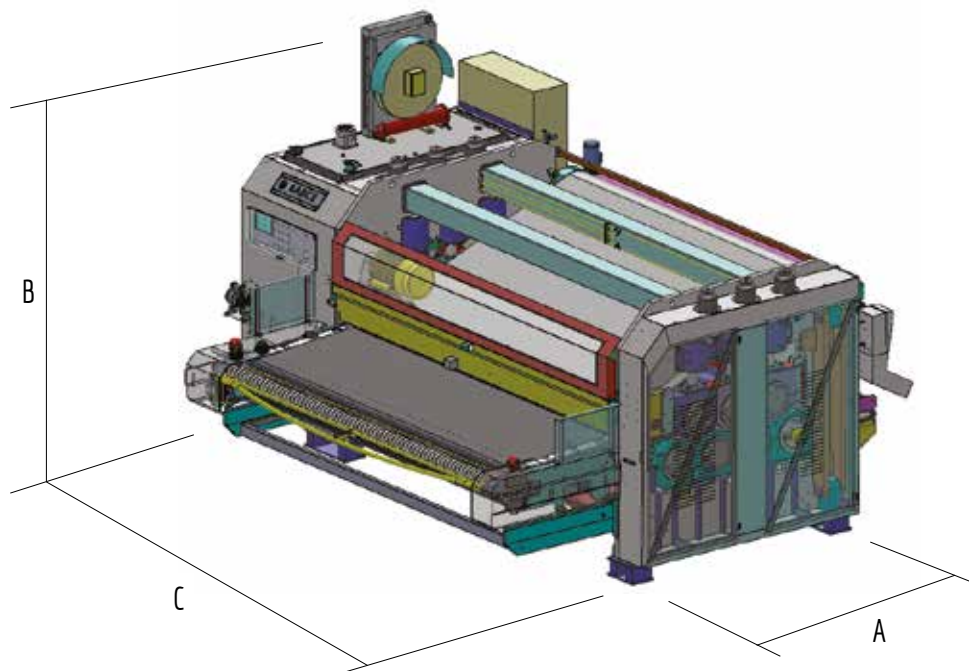

BLUEXTREME 1S

DATI TECNICI / TECHNICAL DATA

VELOCITÀ / SPEED	m/min (50hz)	8÷25	8÷25	8÷25
	m/min (60hz)	10÷30	10÷30	10÷30
POTENZA / INSTALLED POWER	kW	95	95	95
PRESSIONE D'ESERCIZIO POMPA IDRAULICA HYDRAULIC PUMP PRESSURE	bar	50 ÷ 240	50 ÷ 240	50 ÷ 240
OLIO / OIL	Kg	400	400	400
AL. ELETTRICA / POWER SUPPLY	vedere dati di targa della macchina			
AL. PNEUMATICA / PNEUMATIC SUPPLY	bar	6	6	6
CONSUMO ARIA MEDIO / NOMINAL AIR CONSUMPTION	Lt/m	0,1	0,1	0,1
AL. ACQUA / WATER CONNECTION	bar	2	2	2
CONSUMO ACQUA / WATER CONSUPTION	Lt/m	105	110	120
LARGHEZZA DI LAVORO / WORKING WIDTH	mm	3000	3200	3400
PROFONDITÀ / DEEPTH [A]	mm	4270	4270	4270
ALTEZZA / HEIGHT [B]	mm	3080	3080	3080
LARGHEZZA / LENGTH [C]	mm	5010	5210	5410
PESO NETTO TOT. / TOTAL NET WEIGTH	Kg	28200	30000	31900
PESO TOT. IMBALLO / TOTAL WEIGHT	Kg	28250	30050	31950
VOLUME CON IMBALLO MARITTIMO VOLUME WIDTH SEA PACKING	m ³	29	30	31

BAUCE TRI.MA SRL



Head office:

Via del lavoro 27, 36070 Trissino VI ITALY



Tel. +39 0445 490740

Fax +39 0445 490068



info-line@bauce.com

www.bauce.com

Operating Unit:

Via Arzignano 33, 36070 Trissino VI ITALY

R&D Department:

Via dell'artigianato 20, 36070 Trissino VI ITALY

Bauce do Brasil

Endereço: Av. Bom Jardim, 1777, Ivoti - RS BRASIL

Tel.: +555135560555

